

2019 Temecula Regional Contest Information

Facility: Great Oak High School
32555 Deer Hollow Way
Temecula, CA 92592

Ticket Prices/Info

Prelims—\$15
Finals—\$15
Combo—\$25

Please make all checks for tickets payable to Great Oak High School Band Boosters.

EMERGENCY CONTACT (Day of show only)

Brian Johnson - 651-231-7799

General Contest Info

TO LISTEN TO JUDGES COMMENTARY: Each director should be set up with an account through CompetitionSuite. This is the **ONLY WAY** to receive judge's commentary for any WGI event. Instructions to do this are available [here](#).

TARPS: No unfolded performance tarps allowed in parking lots. As long as space allows without violating any fire codes, you may use a practice tarp and it must be labeled "Practice." Violation of this policy is subject to penalty.

INSPECTION: Located in prop unloading (staging).

WARM-UP AREA: All maps are in this packet. Ensembles should report one hour prior to performance time.

PRELIM SCORES: Posted in the gym lobby area.

CRITIQUE: You **MUST** sign up for your critique time upon check in. Please see schedule for critique start time.

RECAPS AND FINALS INFO: Pick up 20 minutes after conclusion of your class prelims at the announcer's table.

FINALS SCHEDULE: The finals schedule will be made available to you after it has been determined.

VIDEO TAPING: No video cameras will be allowed in any contest venue and no authorized space will be provided for groups to record their performance. Any liability associated with unauthorized recordings will rest with the individual or organization making the recording. WGI does not condone, nor accept any liability for, any unauthorized recording during the event.

BOOSTER SALES: Please contact Jerry Burdick-Rutz at jburdick-rutz@tvusd.k12.ca.us.

PLEASE NOTE: WGI enforces a **NO SMOKING** policy at all WGI Regionals, including practice facilities.

Don't forget to check out the [Regional Reminders!](#)





Accessing Judge Commentary

You must have already activated your Competition Suite Account Profile in order for you to be able to listen to WGI judge commentary.

From a Smart phone:

Download the Commentary app:

- Apple: <https://itunes.apple.com/us/app/competitionsuite-commentary/id594112091?ls=1&mt=8>
- Android: <https://play.google.com/store/apps/details?id=com.competitionsuite.commentary>

From the website:

1. Visit <http://competitionsuite.com/login/> and log in using the password you set up in your CompetitionSuite profile.
2. Click on "Performances" on the left side of the page under your group's name.
3. Click on the appropriate commentary file you'd like to download or listen to.

Support

If you have questions, feel free to contact support at help@competitionsuite.com.

WGI Temecula Regional Great Oak HS Temecula, CA



GREAT OAK HIGH SCHOOL

TEMECULA VALLEY UNIFIED SCHOOL DISTRICT

STUDENT/STAFF PARKING/DROP OFF/TRAFFIC FLOW MAP

SITE PLAN

BAND BUS & TRUCK ROUTE

IF YOU ARE PARKING ACROSS THE ST
AT THE PARK, BE SURE TO USE THE
CROSSWALKS

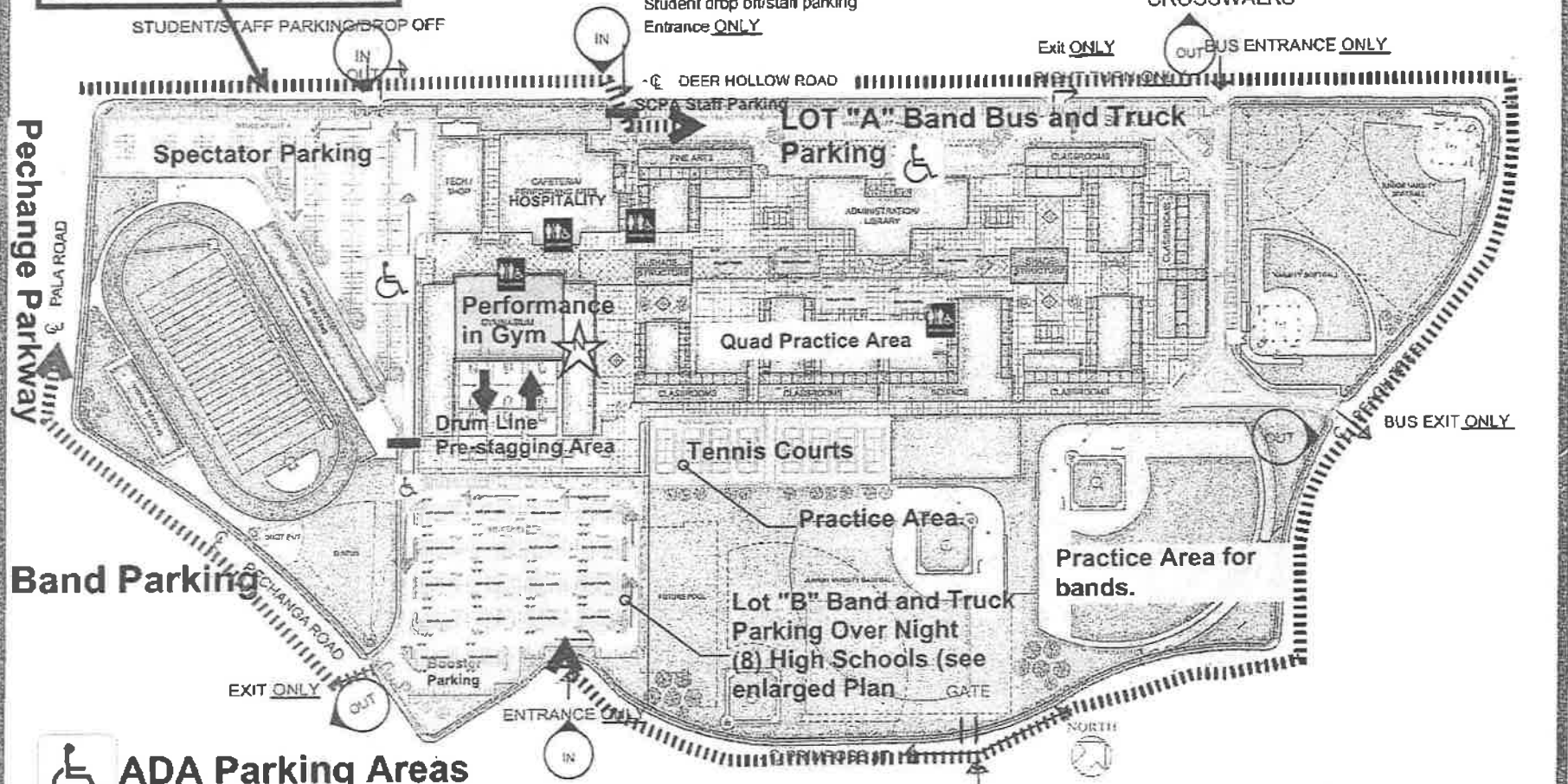

Perchange Parkway
PALA ROAD

Band Parking
PECHANGA ROAD

ADA Parking Areas

Restrooms

GUEST MAP & INFORMATION

PLEASE FOLLOW TRAFFIC
DIRECTIONS AND WATCH
YOUR SPEED

FRICK, FRICK & JETTE
ARCHITECTS, INCORPORATED
15337 BONANZA ROAD
VICTORVILLE, CA 92382
WWW.FFJ-ARCH.COM



Bus and Truck specs regarding overnight parking lot.

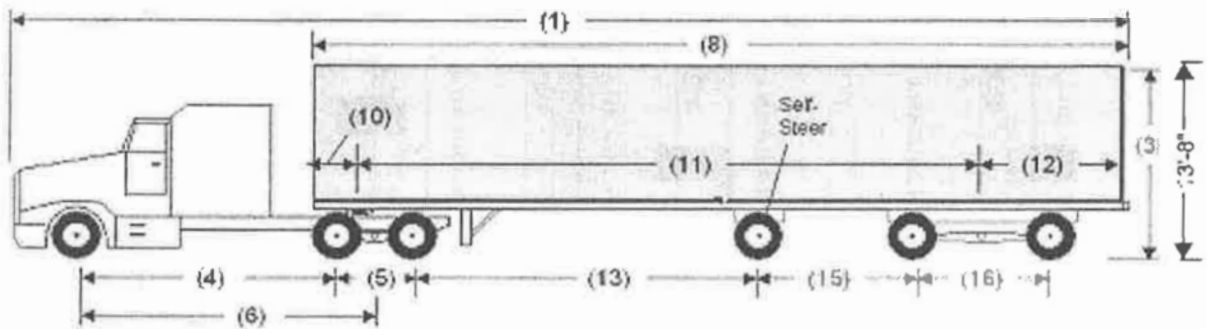

SOLAR PANEL

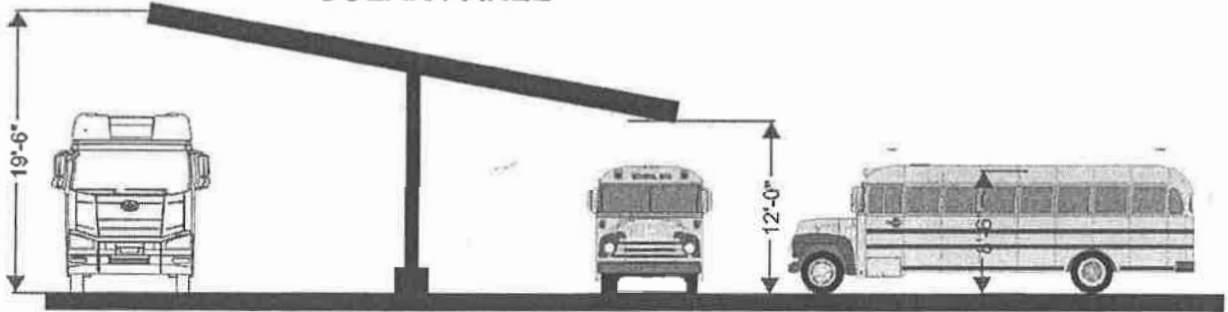



Temecula Regional Competition Area Great Oak HS, Temecula, CA

All WGI contest sites must have a minimum of seventy by one hundred feet (70' x 100') to accommodate a "safety zone" of five (5) feet from any spectator seating. If no spectators are seated on the left and right sides, then the safety zone will be eliminated on the left and right sides of the competition area and extend to the wall.

The "competition area" at this event measures 106' X 72'. All performing groups must be prepared to perform within that area. Floors (tarps) may not extend into the safety zones per rules found in the WGI Adjudication Manual and Rulebook

